

Learn About ...

SODIUM HYDROGEN CARBONATE & SODIUM CARBONATE

One important industrial process is the Solvay process in which sodium hydrogen carbonate (sodium bicarbonate, NaHCO_3) and sodium carbonate (soda ash, Na_2CO_3) are produced from ammonia, carbon dioxide, water, and concentrated brine solution. The Solvay process is significant because it uses inexpensive and plentiful raw materials to prepare useful chemicals. The overall chemical reactions that occur in the Solvay process are represented by the following two equations.

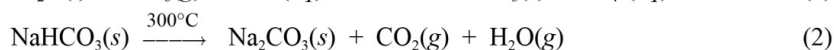
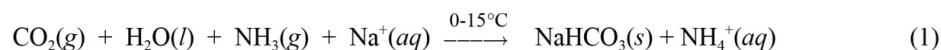

The carbon dioxide produced in the second reaction is recycled to generate more NaHCO_3 . The figure contains a schematic diagram of the manufacturing process.

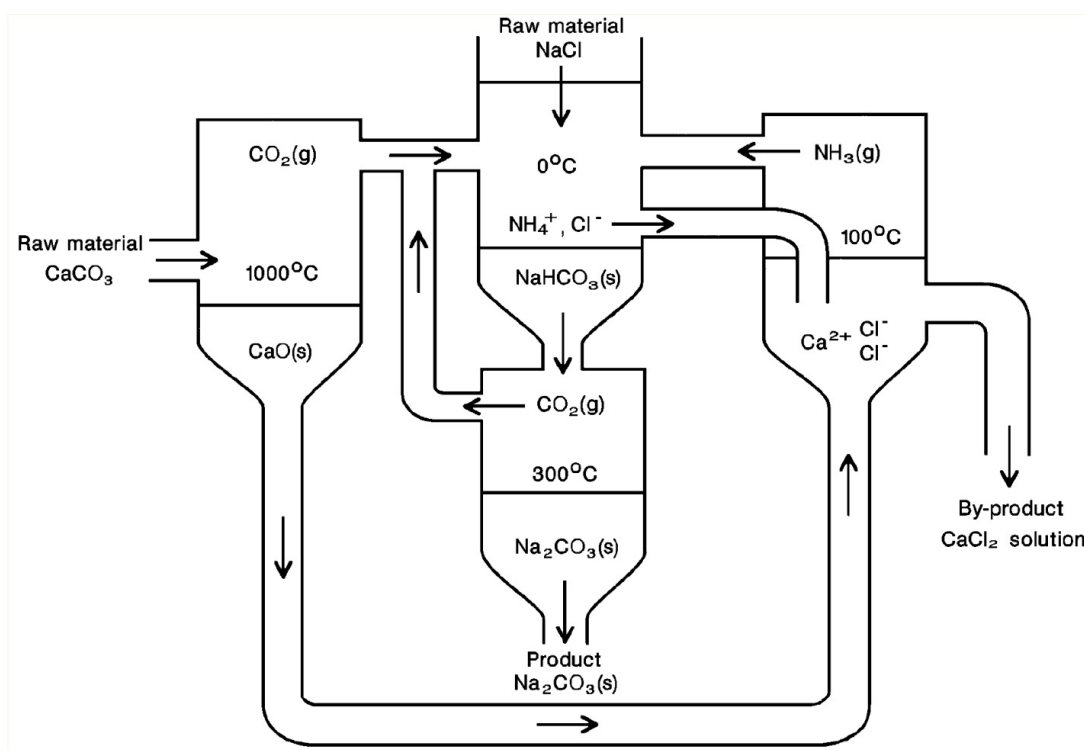

One of the raw materials for the process is limestone (calcium carbonate, CaCO_3). Limestone is heated to produce carbon dioxide.

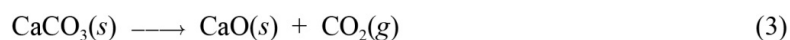

The carbon dioxide is dissolved in water. When it dissolves, some of it forms carbonic acid, H_2CO_3 .

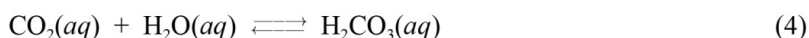

Some of the carbonic acid dissociates, producing hydrogen carbonate ions.

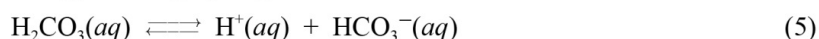

Another chemical used in the process is ammonia, NH_3 . When ammonia is added to aqueous CO_2 , it reacts with hydrogen ions.

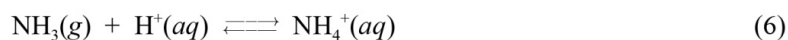

This reaction shifts the equilibria of equations (4) and (5) to the right. The net result is the formation of an aqueous solution of ammonium hydrogen carbonate, NH_4HCO_3 . Another raw material is sodium chloride, NaCl . When NaCl is added to aqueous NH_4HCO_3 , a precipitate of sodium hydrogen carbonate, NaHCO_3 , forms. Sodium hydrogen carbonate is the least soluble of the substances in the mixture (0.82 mol/L at 0°C , compared to 1.5 mol/L for NH_4HCO_3 , 5.5 mol/L for NH_4Cl , and 6.1 mol/L for NaCl).



What remains in the solution is aqueous ammonium chloride. This is mixed with CaO , the byproduct of reaction (3), to release ammonia gas, which is recycled.

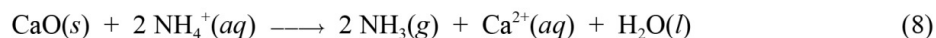

This recycling of ammonia is an essential feature of the Solvay process. The ammonia used to produce sodium bicarbonate is worth more than the sodium bicarbonate. Were it not for the recycling of ammonia, the Solvay process would be economically impractical. Sodium hydrogen carbonate is used in medicine (frequently as an antacid), as a leavening agent in baking (it is “baking soda”), and in the manufacture of sodium carbonate, Na_2CO_3 . “Baking powder” is a mixture composed mainly of NaHCO_3 . In addition, it contains anti-caking agents such as starch and weak acids such as alum or tartaric acid. These weak acids react with sodium bicarbonate, releasing CO_2 gas which causes cake batter and bread dough to rise and produces the tiny holes in cakes and breads. Sodium hydrogen carbonate dehydrates when it is heated, forming sodium carbonate.

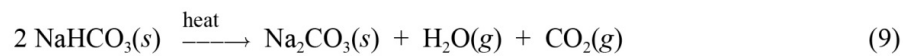

The CO₂ can be recycled to produce more NaHCO₃ by the Solvay process. In recent years, only about 15% of Na₂CO₃ was produced by the Solvay process. The remainder was mined from large deposits of trona, Na₂CO₃•NaHCO₃•2H₂O, which were discovered in 1938 near the Green River in Wyoming. It is cheaper to mine Na₂CO₃ than to manufacture it. Furthermore, the CaCl₂ by-product of the Solvay process has not found sufficient use as a chemical to enhance the economic value of the Solvay process. About 11.3 million tons of Na₂CO₃ are produced annually. Sodium carbonate is a fairly strong, non-volatile base which is used in the manufacture of glass (55%), paper (5%), soap, and many other chemicals (25%). Sodium carbonate is also called soda ash and washing soda. Sodium carbonate is used in laundry detergents as a softening agent. The carbonate ions from dissolved sodium carbonate precipitate magnesium and calcium ions from hard water. These metal ions would otherwise combine with soap or detergent and form an insoluble scum that would stain the laundered clothes.