

# Connecting Chemistry to Society and Fostering Community Appreciation of Science



**Professor Bassam Z. Shakhashiri**

William T. Evjue Distinguished Chair for the Wisconsin Idea  
Director, Wisconsin Initiative for Science Literacy

**SCIENCE IS FUN**  
In the Lab of Shakhashiri

**Department of Chemistry**  
**University of Wisconsin-Madison**

**ACS Southeastern Regional Meeting**

**Puerto Rico • Thursday, October 20, 2022**

# Classroom

# Public Engagement



**SCIENCE IS FUN**  
In the Lab of Shakhashiri

**What differentiates our  
society now from all  
previous societies?**



# Science



**SCIENCE IS FUN**  
In the Lab of Shakhashiri



# Industrial Revolution

# Electronic Revolution



**SCIENCE IS FUN**  
In the Lab of Shakhashiri

# New Discoveries

Enlightenment

Societal Progress

Societal Problems





**SCIENCE IS FUN**  
**In the Lab of Shakhashiri**



**SCIENCE IS FUN**  
**In the Lab of Shakhashiri**

**“Science and society have what is essentially a social contract that enables great intellectual achievements but comes with mutual expectations of benefiting the human condition and protecting our planet.”**





# Science is Vital to Democracy



*“Public sentiment is everything.  
With public sentiment,  
nothing can fail;  
without it nothing can succeed.”*

**>> Abraham Lincoln**





**(IN EVERY ELECTION)**





# Grand Challenges to Society and to Scientists

Help sustain Earth and its people in the face of:

- Climate Change
- Population Growth
- Finite Resources
- Malnutrition
- Spreading Disease
- Deadly Violence
- War
- Denial of Basic Human Rights, *especially the right to benefit from scientific and technological progress*



**Warming Is**



**Unequivocal**

# Greenhouse gases absorb infrared radiation

Composition of Dry Air

Component	Composition	Content (%)
Nitrogen	N <sub>2</sub>	78
Oxygen	O <sub>2</sub>	21
Argon	Ar	0.94
Trace Gases	-	0.10%

Greenhouse Gases

Component	Composition	Content (%)
Carbon Dioxide	CO <sub>2</sub>	0.040
Methane	CH <sub>4</sub>	0.00018
Nitrous Oxide	N <sub>2</sub> O	0.000033
Water Vapor	H <sub>2</sub> O	0.0-4.0

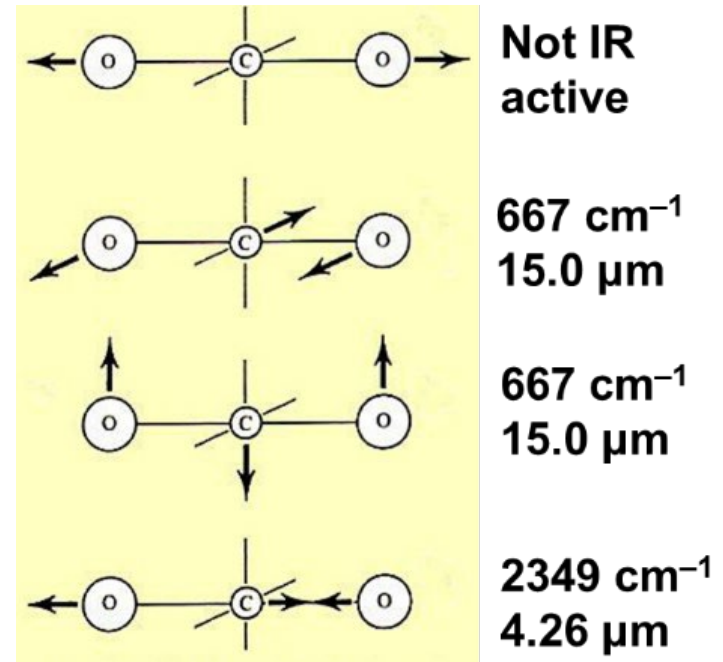

CO<sub>2</sub> molecular vibrations

The Engines of Our Ingenuity, Episode 1776, John H. Lienhard, University of Houston



\*Latest CO<sub>2</sub> reading: 415.57 ppm

## Carbon dioxide concentration at Mauna Loa Observatory

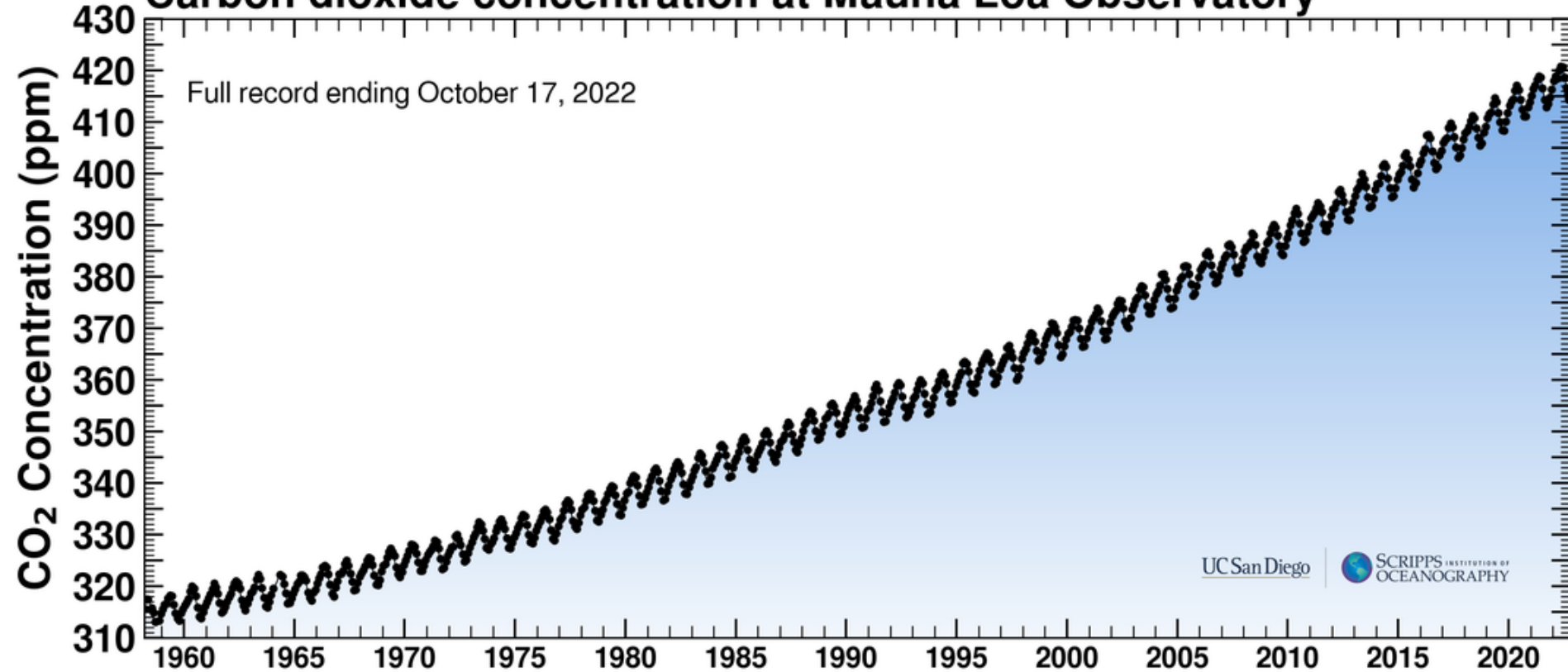

**SCIENCE IS FUN**  
In the Lab of Shakhashiri



\*Latest CO<sub>2</sub> reading: 415.57 ppm

## Carbon dioxide concentration at Mauna Loa Observatory

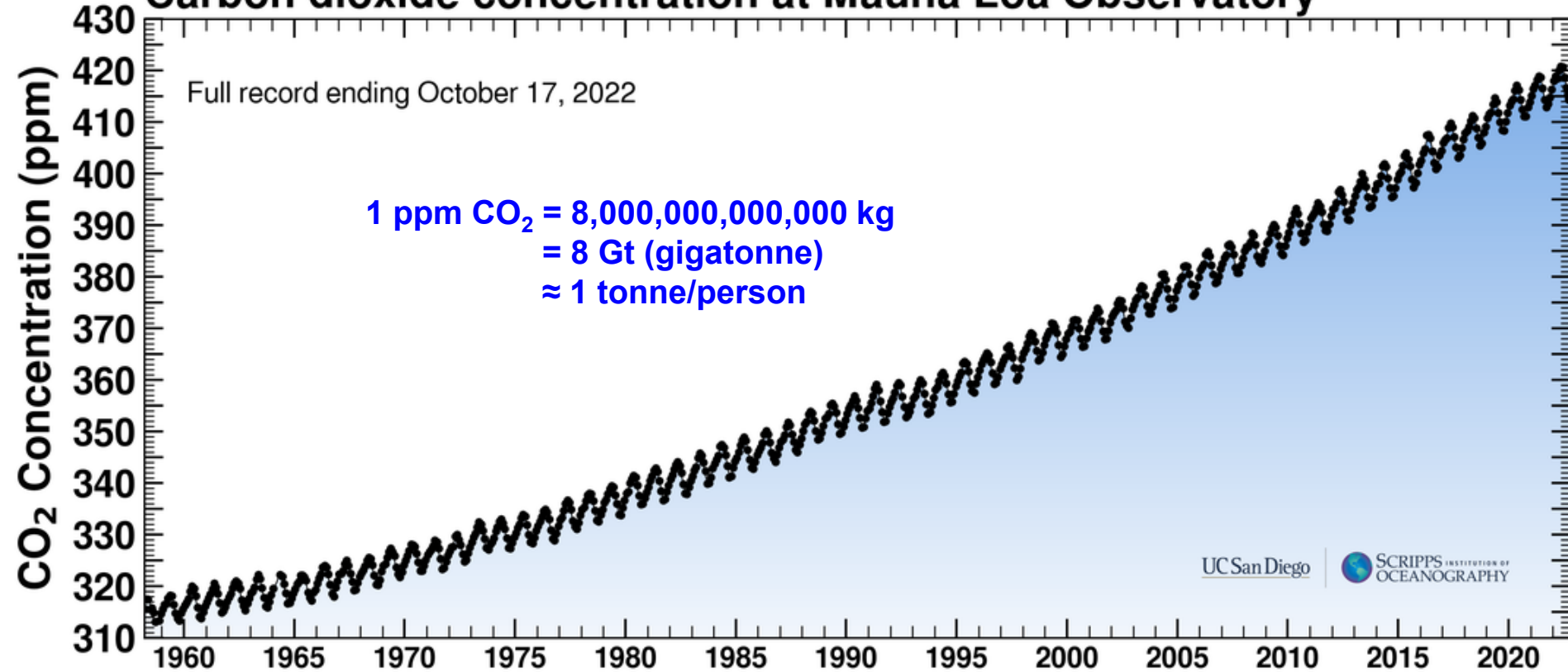

**SCIENCE IS FUN**  
In the Lab of Shakhashiri

# PLANT HARDINESS ZONES

These maps display measurements taken to help farmers and gardeners with their planting. The differences between the two maps show that Wisconsin is getting warmer. This is a telltale of global warming and an indicator of how the climate is changing.

**1980-1999**

The two-decade span reflects the average of the measurements taken during this time period.

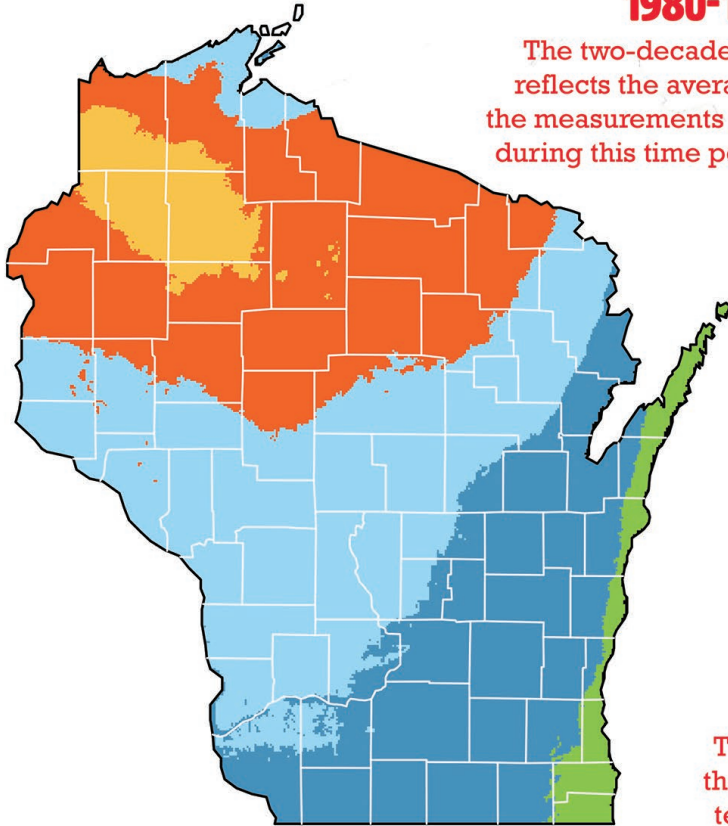

**2000-2018**

The two-decade span reflects the average of the measurements taken during this time period.

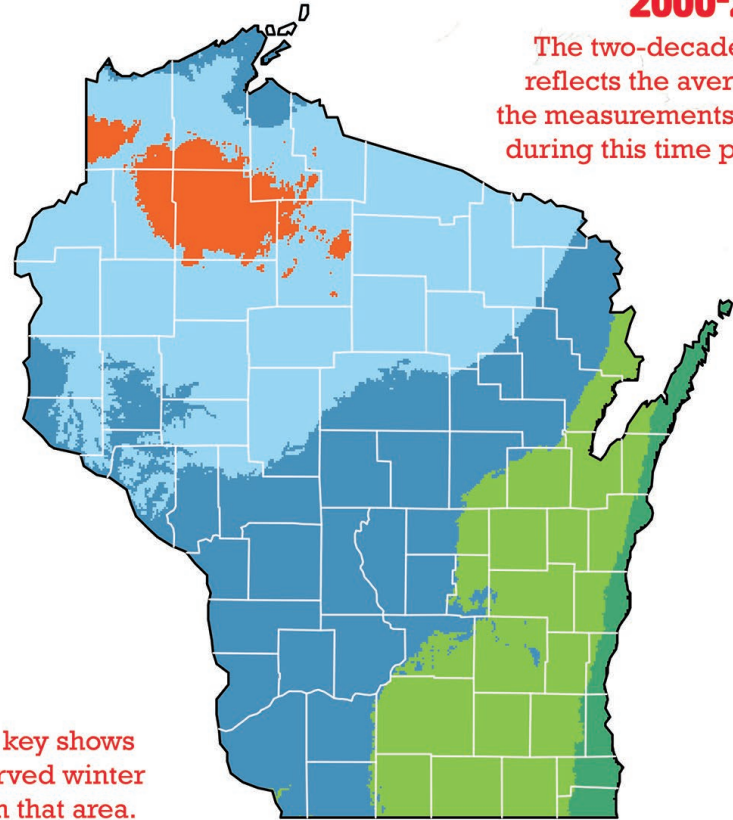

The zone color key shows the lowest observed winter temperatures in that area.

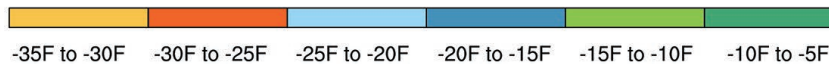

**SCIENCE IS FUN**  
In the Lab of Shakhashiri

# Lake Mendota Ice On and Off Dates, 1855-2022

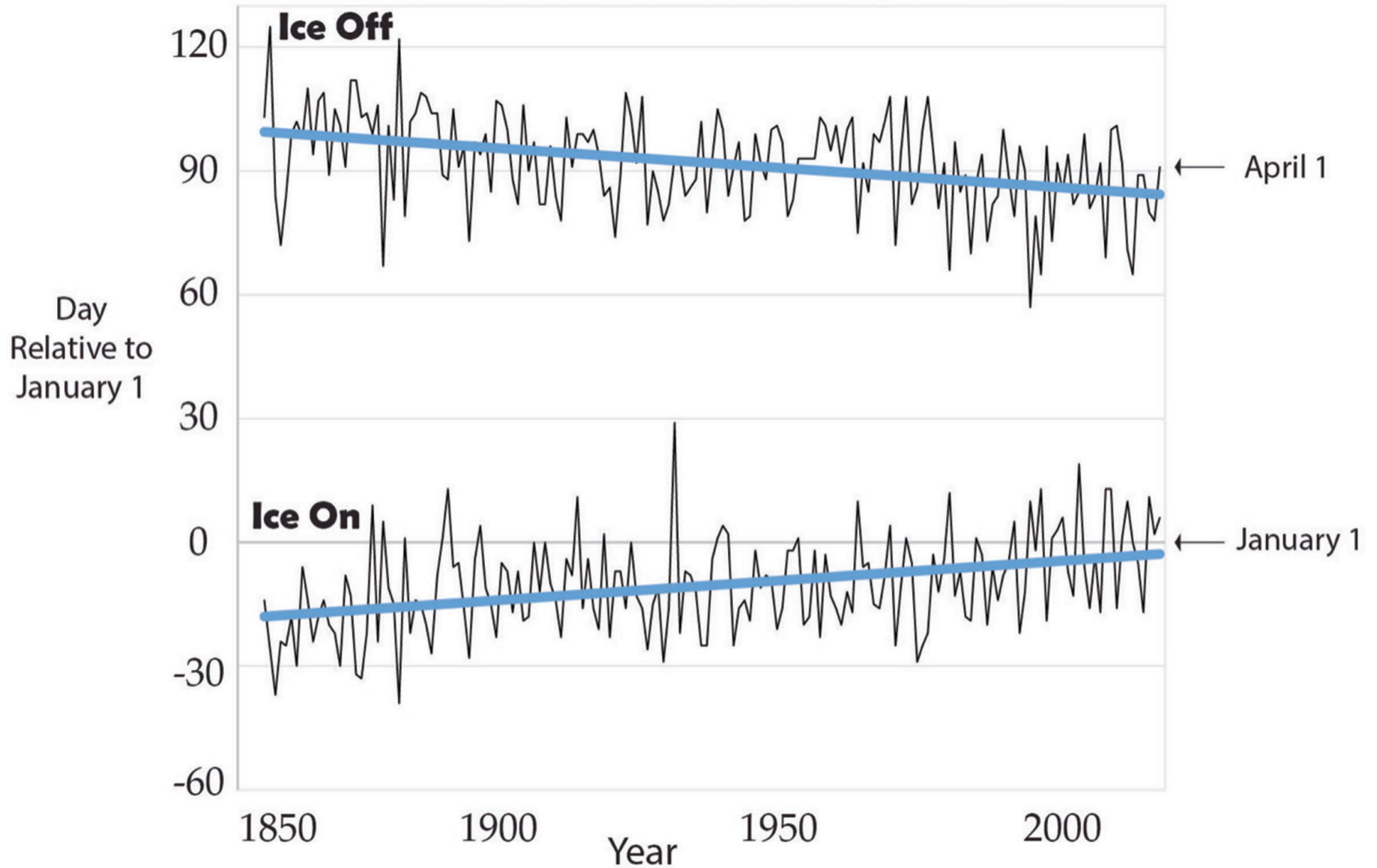

# Climate Science Concepts Fit Your Classroom: A Workbook for Teachers

The Workbook is free and accessible to all on my website:  
[scifun.org/ClimateWorkbook/home.html](http://scifun.org/ClimateWorkbook/home.html)





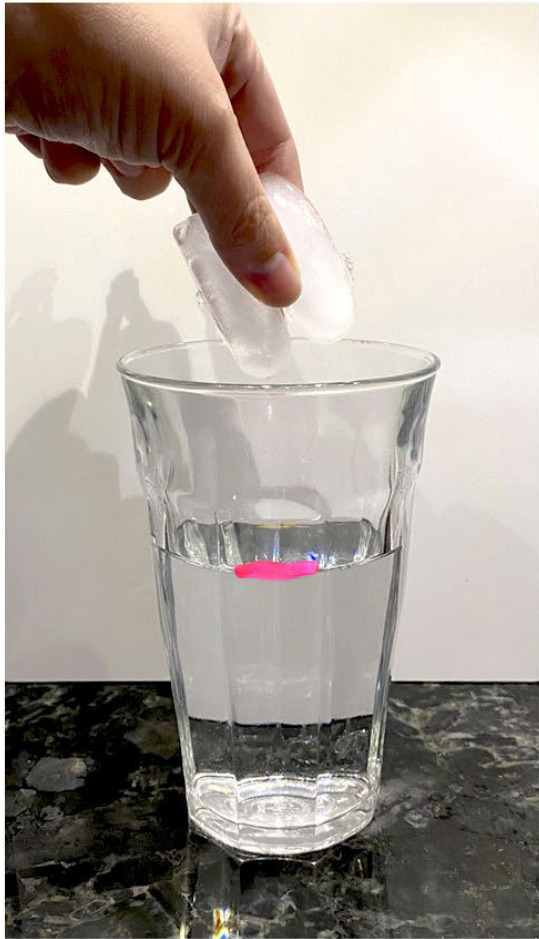

**SCIENCE IS FUN**  
**In the Lab of Shakhashiri**



# Sea Level Rise

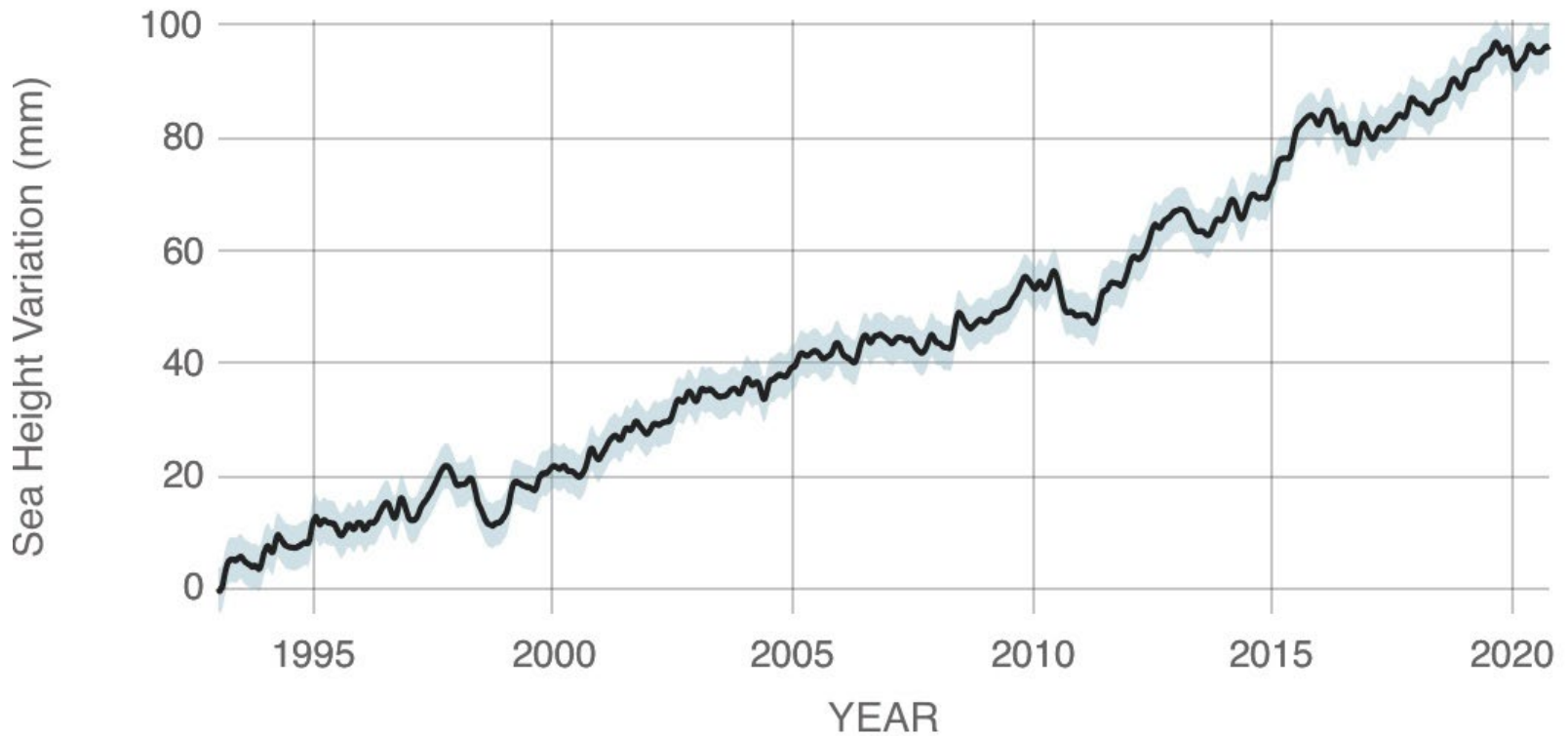

Source: [climate.nasa.gov](http://climate.nasa.gov)



**SCIENCE IS FUN**  
In the Lab of Shakhashiri

# Personal and Community Action: What can you do?

- Increase your scientific knowledge of climate change.
- Commit to taking responsible action to help mitigate global warming.
- Engage your family, friends, and others in conversations about global warming.
- Be respectful, trustworthy, and confident in what you say about global warming.
- Keep in touch with us electronically at [scifun@chem.wisc.edu](mailto:scifun@chem.wisc.edu)





# Personal and Community Action: What can you do?

- Buy less stuff. (Reduce/Reuse/Recycle)
- Change those light bulbs. (And turn them off.)
- Use a programmed thermostat.
- Eat less meat. (Especially beef)
- Walk, bike, use more public transportation. Fly less.
- Switch to a car with better fuel economy or an electric vehicle.

**RAISE YOUR VOICE**



*And recruit at least five eligible voters who haven't voted.*

**IN EVERY ELECTION!**

**SCIENCE IS FUN**  
In the Lab of Shakhashiri





# Scientific Competence

Scientific Expertise

Science Literacy



“Science literacy does not imply detailed knowledge of chemistry or physics or biology, but rather a broad understanding and appreciation of what science is capable of achieving and, equally important, what science cannot accomplish.”





“Science literacy will enable the public to make informed choices and to reject shams, quackery, unproven conjecture, and to avoid being bamboozled into making foolish decisions where matters of science and technology are concerned.”



**“We must assure that the next generation of scientists is both highly skilled technically and properly educated to carry on their scientific and educational work for the common good of society.”**

---

**“In a free and civil society people must be virtuous as well as technically skilled.”**



# CONNECTIVITY



American Chemical Society

**SCIENCE IS FUN**  
**In the Lab of Shakhashiri**

**Students**  
**Classroom Environment**  
**Family and Friends**  
**Neighbors**  
**Community**  
**Elected Officials**  
**The Media**



# Respect

# Trust

# Confidence





**SCIENCE IS FUN**  
**In the Lab of Shakhashiri**









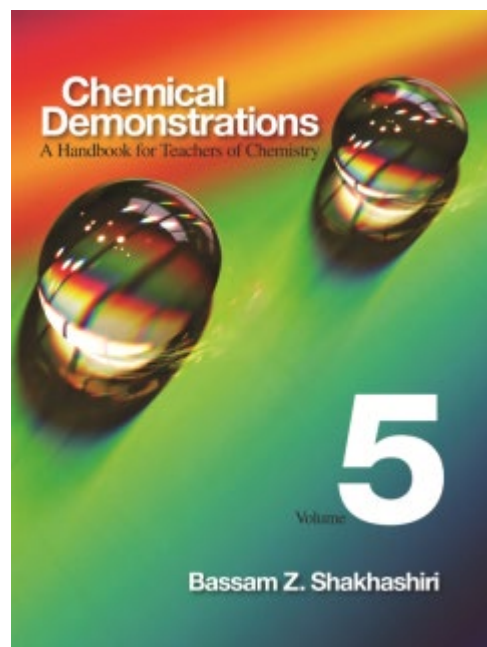
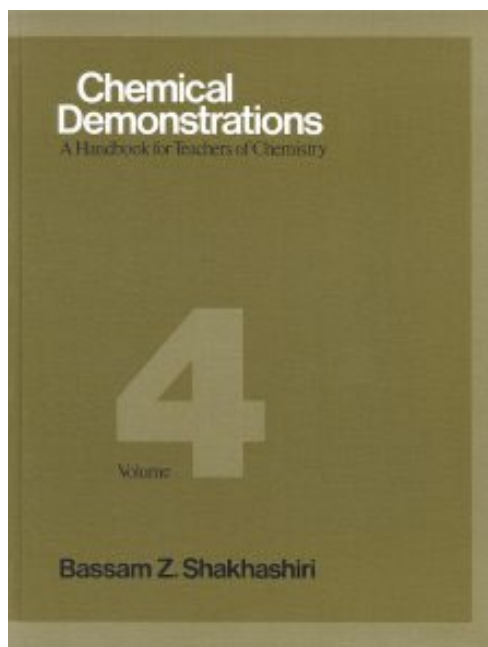
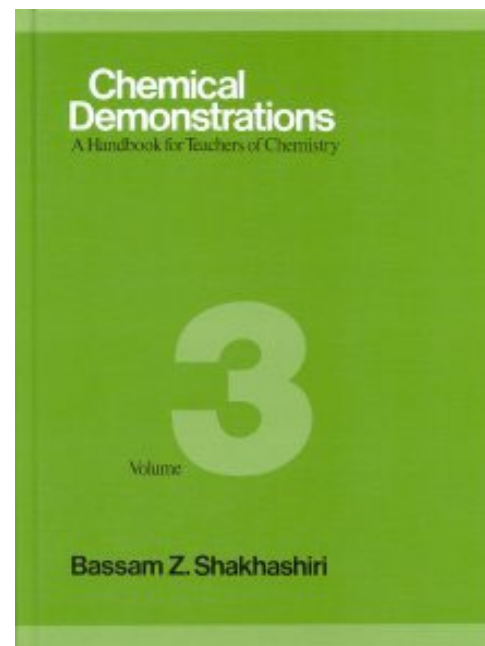
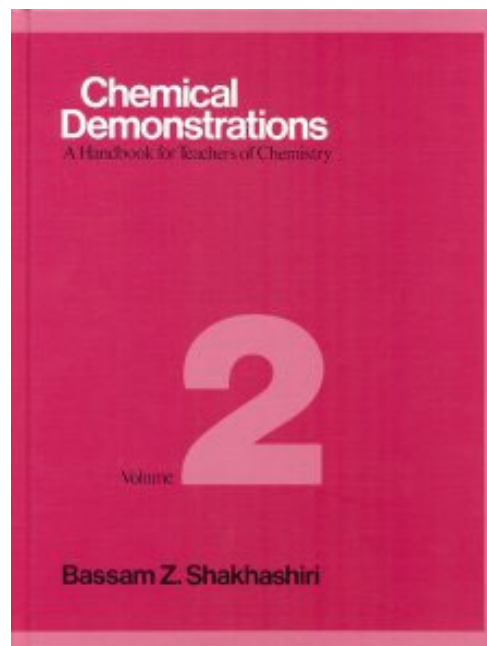
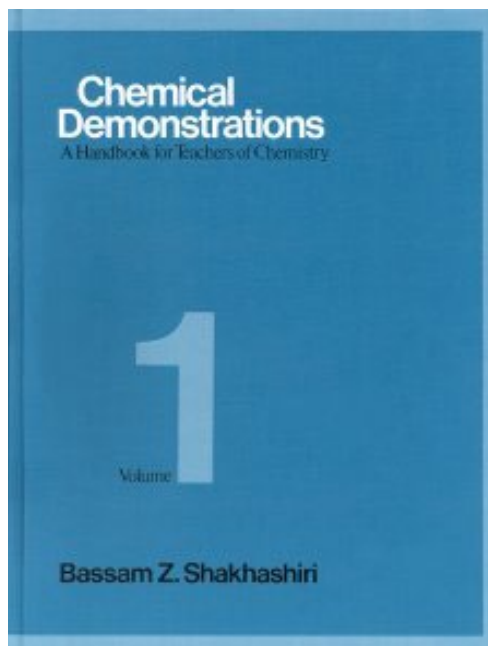

**SCIENCE IS FUN**  
**In the Lab of Shakhashiri**





**SCIENCE IS FUN**

**www.scifun.org**



**SCIENCE IS FUN**  
In the Lab of Shakhashiri